



**SLIM**

**ASSEMBLY INSTRUCTION**

## SLIM COMPONENT LIST

- Main frame:
1. Top rail – Quantity 1
  2. Bottom rail – Quantity 1,
  3. Side rails – Quantity 2
  4. Mitre joiners – Quantity 12
  5. Decorative frame top profile –Quantity 1
  6. Decorative frame bottom profile – Quantity 1
  7. Decorative frame side profiles – Quantity 2
  8. Angle brackets for decorative frame– Quantity 4
- Wall Brackets:
9. Frame brackets – Quantity 2
  10. Wall Z-Brackets – Quantity 2
- Fabric:
11. Enlightor (white) - supplied in cardboard tube
  12. Black backing fabric – supplied folded
- Tools:
14. Spatula – Quantity 1
  15. Hex key – Quantity 1
  16. Plastic foil – Quantity 1
  17. Mallet – Quantity 1
  18. Stiffening bars – Quantity 2

You will also need the following items:

Tape measure, spirit level, sharp scissors, screws and wall plugs for fixing to wall.

The following diagram shows the parts with their corresponding item numbers.

# COMPONENT DIAGRAM

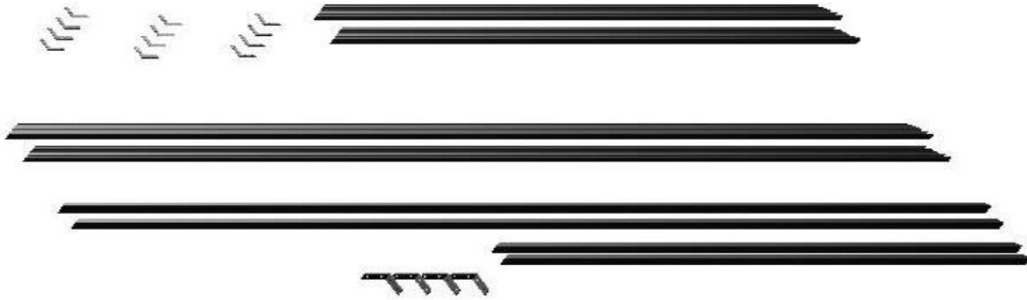

The SLIM 110" and 120" comprise two additional stiffening bars



# ASSEMBLY ADVICE

Clear a space sufficiently larger than the external dimensions of the screen with access to all sides – ideally this should be a clean, flat surface to protect the screen from damage.

Carefully remove all of the components from the packaging and check them against the components list.

Locate the plastic sheet and spread it out onto your clean assembly surface.

A number of the component joints are colour coded with round coloured stickers.

**PLEASE RESPECT THE COLOUR CODING.**

Your screen has been pre-assembled in the factory and the colour coding is important.

Determine the positions of the wall screws (1/4" or 6mm) The lateral position of the frame brackets (item 9) can be changed by loosening the retaining screws and sliding the brackets to the required position. Use wall plugs of suitable size and strength for the screen.

The vertical position of the mounting brackets can be determined from the following diagrams.

# MAIN FRAME ASSEMBLY

1. Lay the main components out on the plastic sheet as shown below.

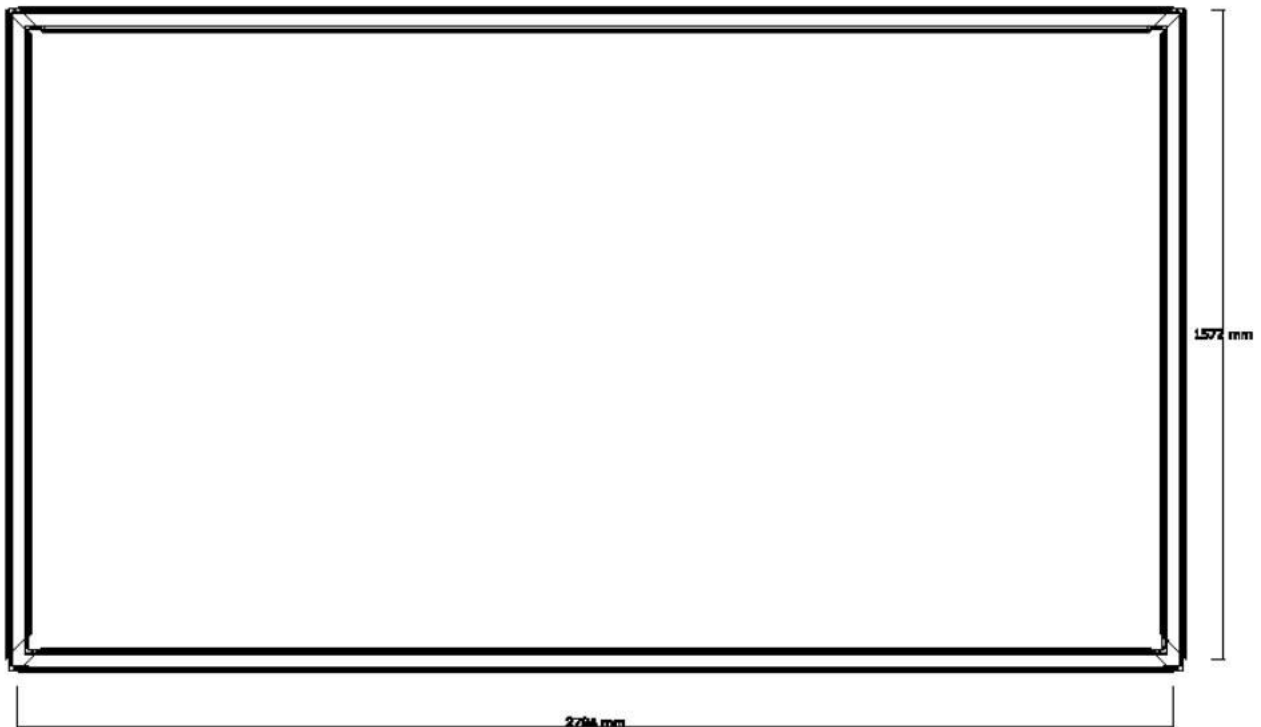

Note: the dimensions are for a SLIM 110

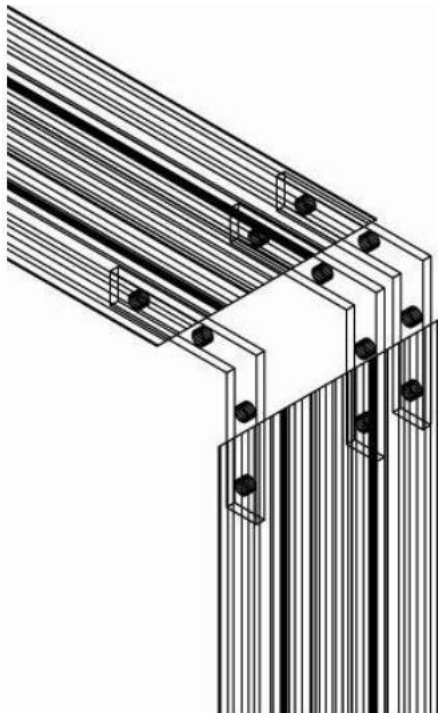

Details of the joining

Slide the corner joiners into place as shown. The joiners may need a gentle tap with the mallet. Then push the profiles, so that the mitred angles join together. Once in place, tighten with the screws with the provided hex key.

ASSEMBLED STRUCTURAL FRAME

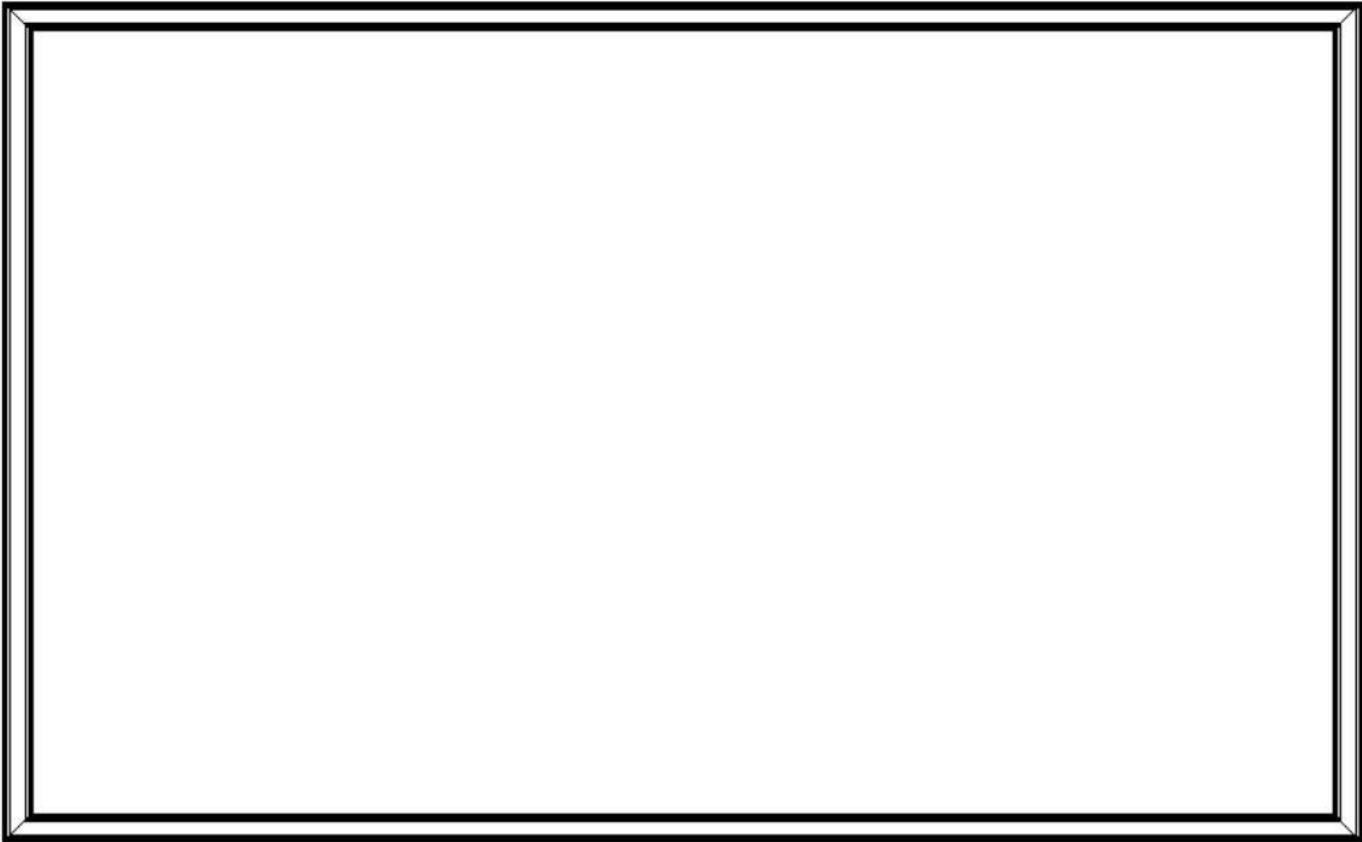

## WALL MOUNTING BRACKETS

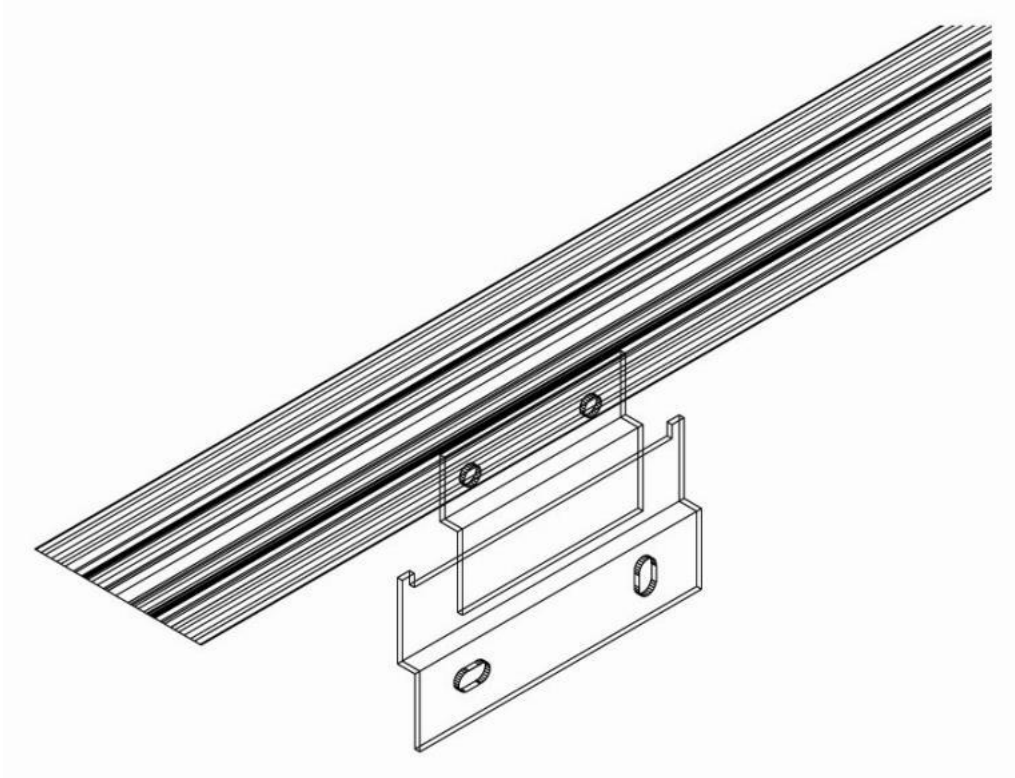

These diagrams show views from behind the screen BEFORE the fabric is fitted

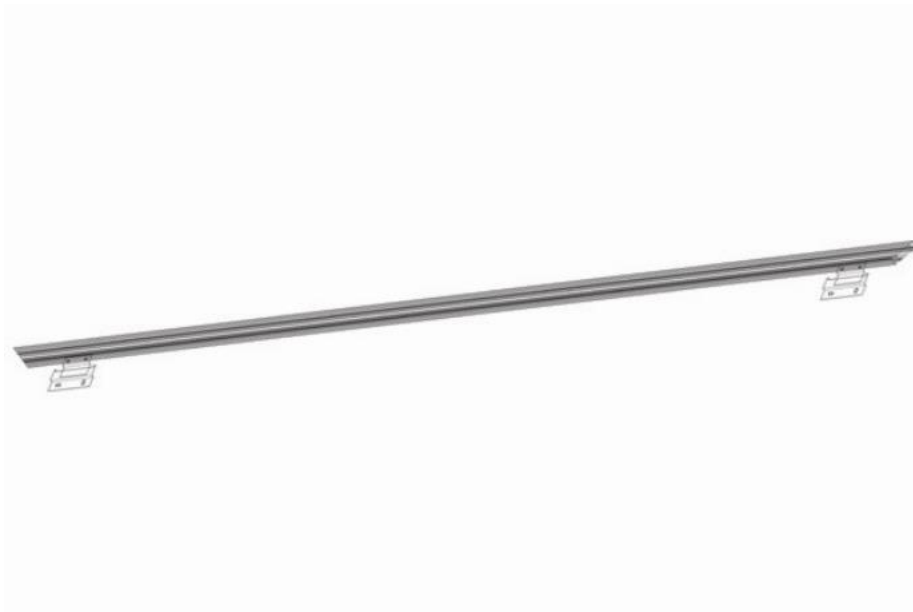

Draw a horizontal line on the wall with a spirit level, then anchor the 2 wall Z-brackets

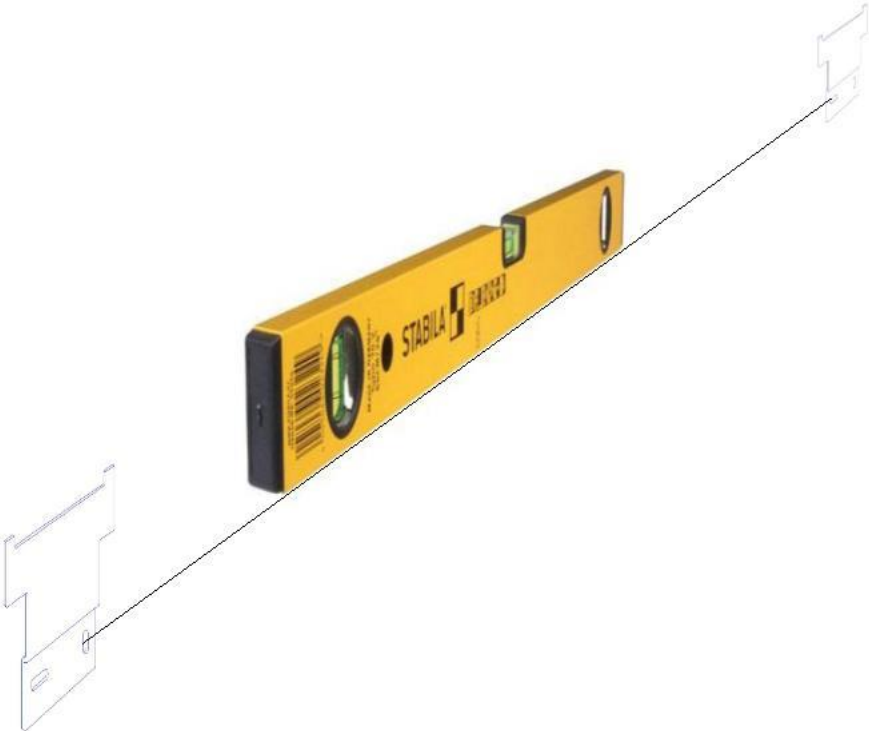



# WALL MOUNTING BRACKETS

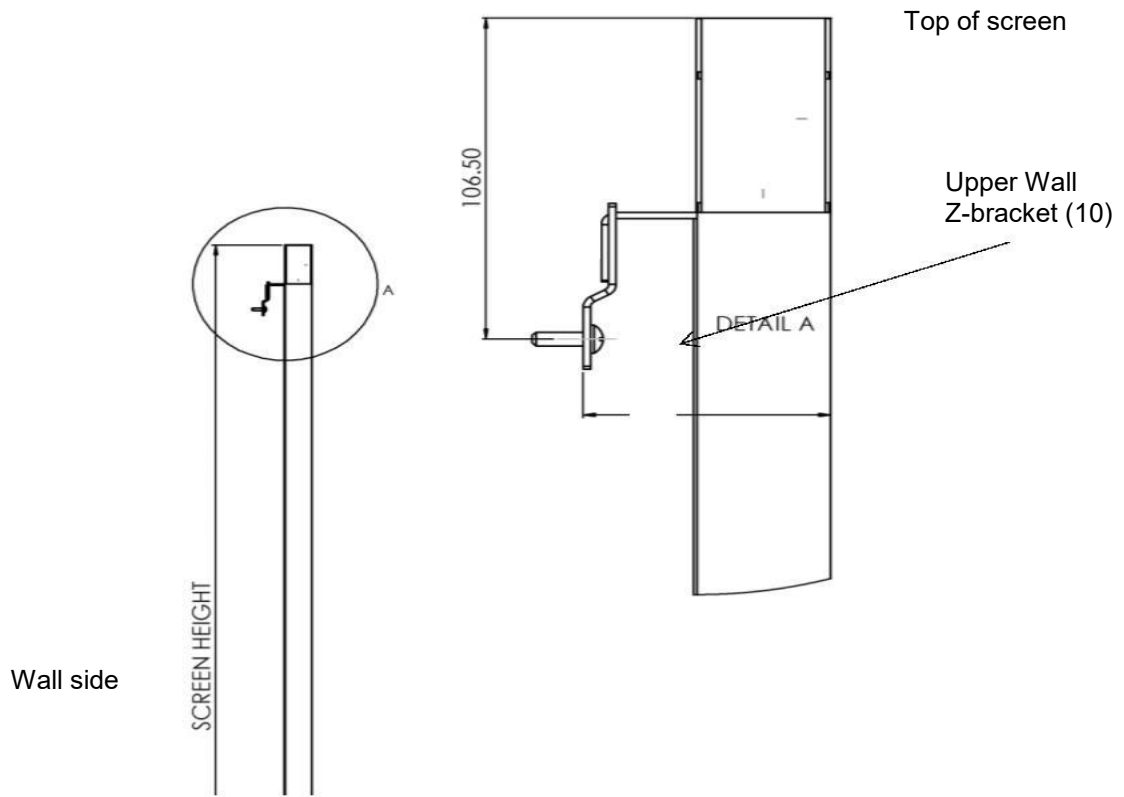

Side view of screen

## FITTING THE BLACK BACKING MATERIAL

Set the finished frame aside and now unfold the black backing fabric and lay it flat on the plastic foil.

ENSURE THAT THE PLASTIC FOIL IS CLEAN AND FLAT – IT IS ALSO WORTH WASHING YOUR HANDS AT THIS POINT TO ENSURE THAT THE FABRICS ARE KEPT AS CLEAN AS POSSIBLE.

Lay the finished screen frame on top of the black fabric with the front face of the frame down, touching the black fabric as shown below.

It is important that the fabric is as smooth and wrinkle free as possible.

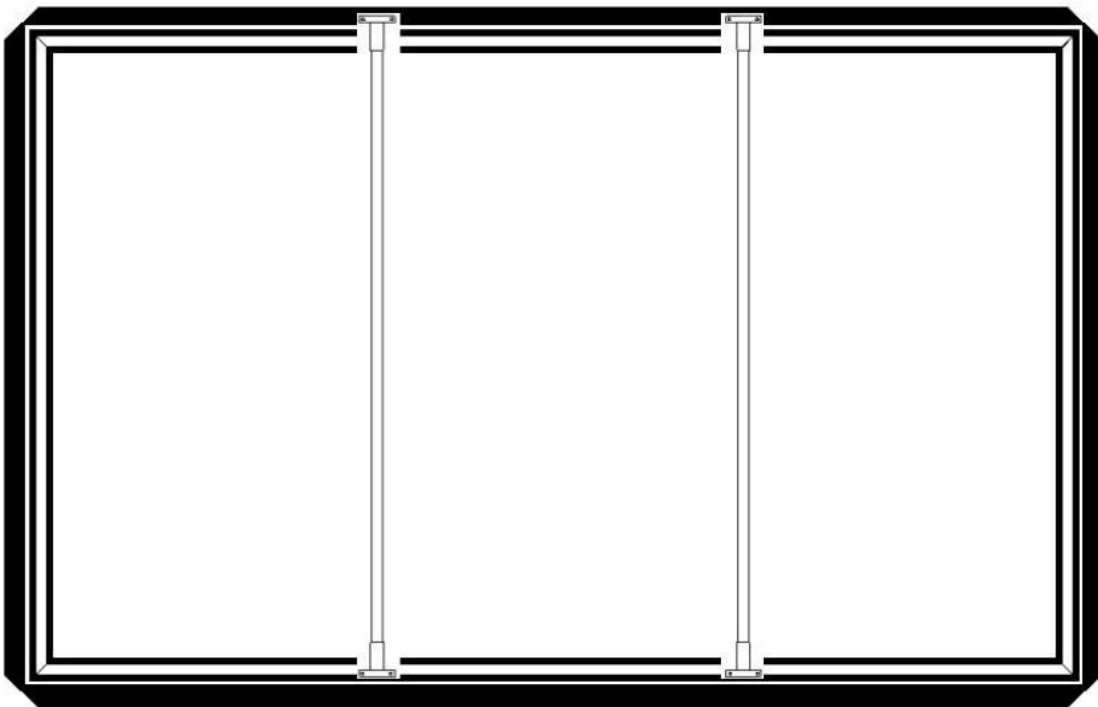

Black fabric laid on plastic foil

Note: On the drawing the 2 stiffening bars have been represented as for a 100" or over base width

Starting from one end, fold the black fabric around the frame as shown carefully folding the corners and ensuring that the fabric is smooth and wrinkle free.

Fold corners neatly

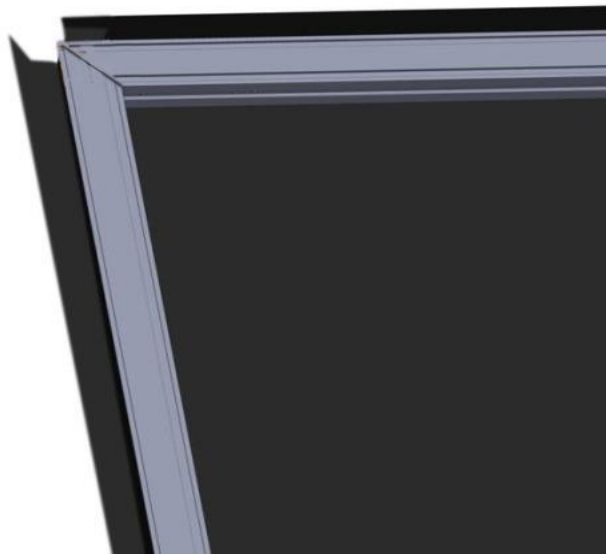
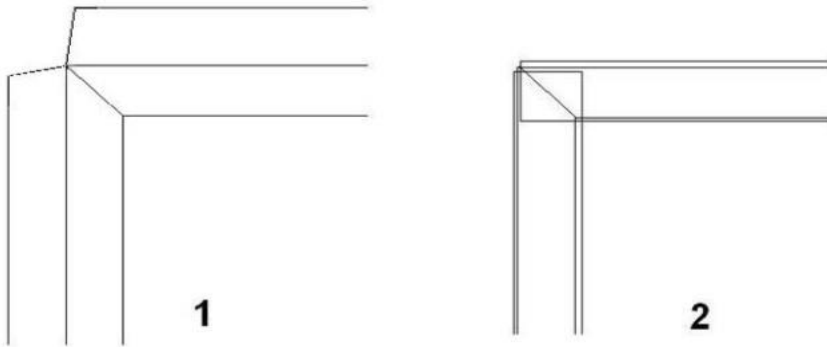

Place provided pi-grip/grip-fix on fabric laying on frame. Using supplied mallet, insert the Black Backing into the groove on the rear face of the frame, trapping the fabric in the groove. The action of pushing the fabric will tension it. Again, ensure that the fabric is smooth and wrinkle free. Do it around frame.

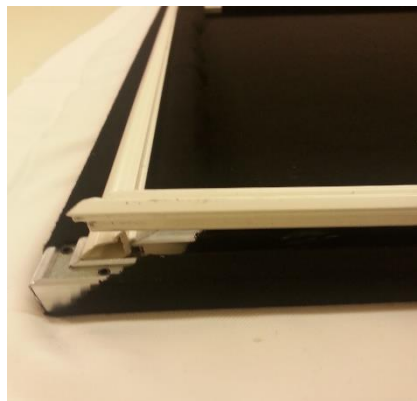

# FITTING THE WHITE PROJECTION SCREEN MATERIAL

## **Note:**

Before inserting the fabric in the grip-fix groove, apply a very slight tension. The progressive insertion into the groove will significantly increase this tension.

To insert the tool in the profile, start from the small straight edge, then gently push the fabric inside the by a rotation movement along the curved edge. Once you have reached the end of the curved edge, take the tool out of the profile and start again.

Check that the tension is sufficiently uniform to avoid uneven bending of the screen frame.

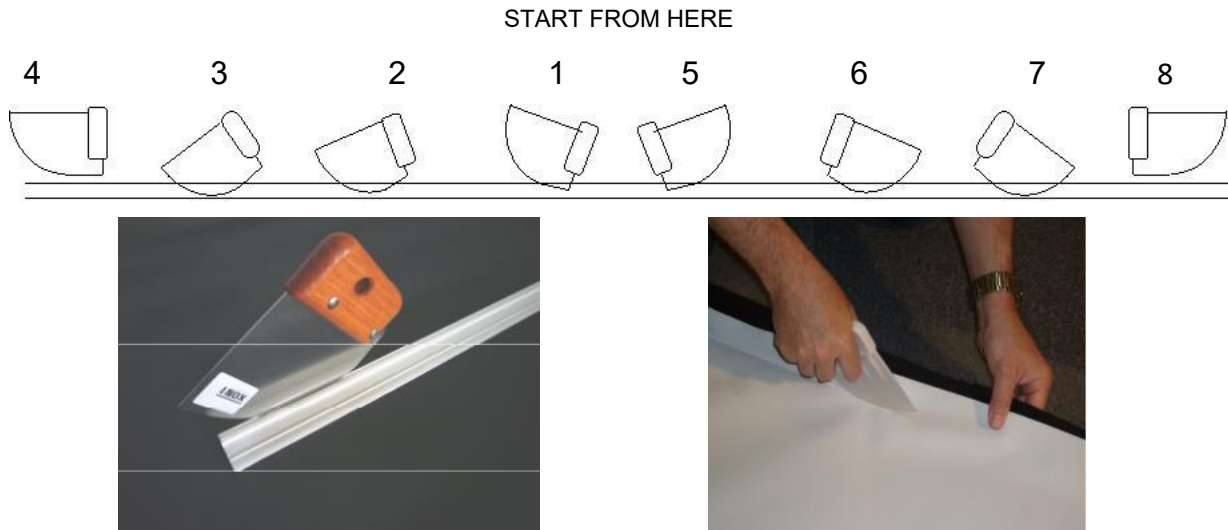

Set the frame aside again and now unroll the white screen fabric and lay it flat on the plastic sheet.

ENSURE THAT THE PLASTIC SHEET IS CLEAN AND FLAT – IT IS ALSO WORTH WASHING YOUR HANDS AT THIS

POINT TO ENSURE THAT THE FABRICS ARE KEPT AS CLEAN AS POSSIBLE.

Lay the screen frame on top of the white fabric with the front face of the frame down, such that the Black fabric is touching the white fabric as shown below.

It is important that the fabric is as smooth and wrinkle free as possible.

You will need to apply the same process as for fitting the black backing . Both fabrics are inserted into the same groove. Fitting of the fabric is best performed with at least two people.

Once you have fitted the white fabric, turn the screen over and carefully inspect the screen surface to ensure that you are happy with the tension and the smoothness of the surface.

If you need to re-tension or remove wrinkles from the fabric, you can carefully remove locally the fabric from the groove by gently pulling horizontally on the external part of the fabric towards the outside of the frame. Then you can re-insert the fabric with the spatula.

Once satisfied with the fit of the fabric, using sharp scissors trim off any excess material but leave at least 20 mm of material all around in-case you ever have to re-tension the screen.

Once you are happy with the screen surface, you need to assemble the external velvet-finished decorative frame around the main frame.

# ASSEMBLING THE EXTERNAL FRAME

Once the main frame is fitted with both the black backing and the white screen fabric, lay it flat on the plastic sheet.

Place the 4 external frame elements around it .

Overall view of external frame

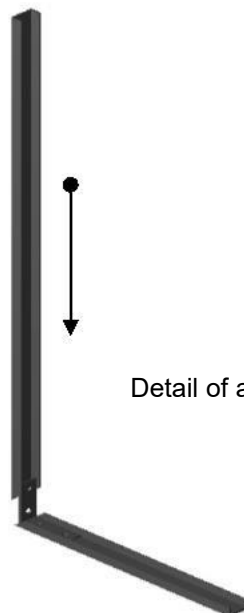
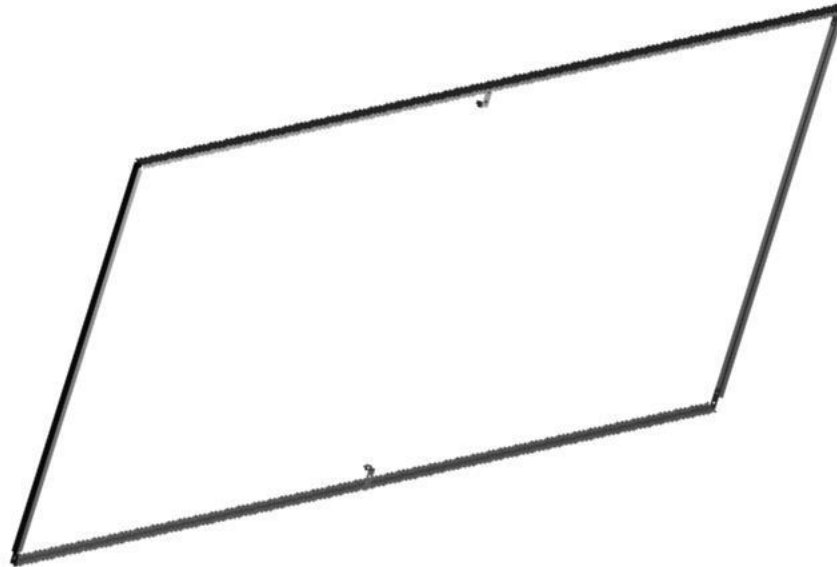

Detail of angle assembling (use provided M4 screws)

Assemble the external frame around the main frame.

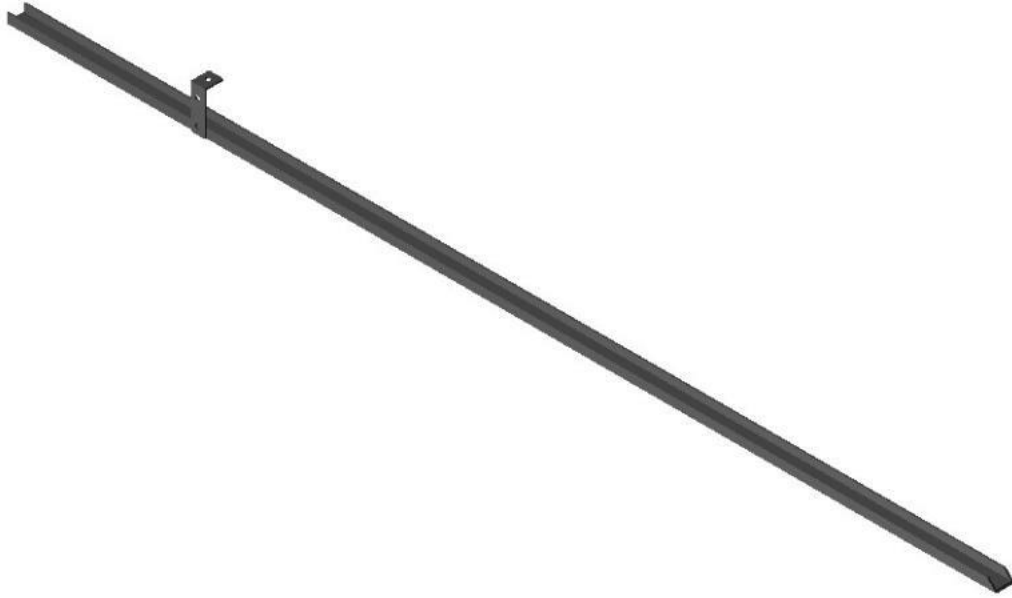

## FINAL



Once the external decorative frame is fitted around the main frame, all that remains is for you to mount the screen onto the Wall brackets.

See page 9

With at least one person at each end of the screen, lift the screen into place and lower it down into the Wall Z-brackets. There is some lateral movement available in the brackets allowing fine positional adjustments to be made.

Then the screen installation is finished.